

# Roppe Metal Treads, Metal Stair Tread Nosings & Metal Flat Step



## Product Data

Section 9  
Resilient Flooring



## 1. Product Nomenclature

Roppe Metal Treads, Metal Stair Tread Nosings & Metal Flat Step.

## 2. Manufacturer

Roppe Corporation  
1602 N. Union Street  
P.O. Box 1158  
Fostoria, Ohio USA 44830-1158  
Phone: 419.435.8546  
Toll Free: 800.537.9527  
Fax: 419.435.1056  
Email: sales@roppe.com  
Web Site: www.roppe.com  
Sweets Catalog: 09 65 00/ROP

## 3. Product Description

### 3.1 Basic Application

Roppe Metal Stair Treads, Metal Stair Tread Nosings & Metal Flat Step are a resilient, anti-slip designed product for installations over both new and existing residential and commercial steps, restaurants, commercial kitchens and landings where an anti-slip surface is desired. The metal stair treads base is constructed of extruded aluminum with a tapered back edge. The Metal Stair Tread's surface face is comprised of front and back channels separated by a thin aluminum divider and each channel is filled with a colored closed cell anti-slip epoxy coating combined with mineral abrasive grits that are uniform through-out providing anti-slip properties. Roppe Treads are also chemical resistant, UV stable and meet A.D.A. recommendations for the Visually Impaired when contrasting colors have been selected per A.D.A. guidelines. The unique design of Roppe Metal Stair Treads two channel face profile allows the consumer the option of selecting one solid color or two color combinations to match commercial or residential color themes, which can be selected from eight unique colors, in addition to custom color matching for an additional fee. Roppe Metal Stair Treads, Metal Stair Tread Nosings & Metal Flat Step are durable enough for industrial applications, but also attractive for residential use, and constructed of heat treated exterior grade aluminum 6063T3 which is resistant to corrosion.

### 3.2 Product Construction

Roppe Metal Stair Treads, Metal Stair Tread Nosings & Metal Flat Step are constructed of heat treated exterior grade aluminum 6063T3 which is resistant to corrosion. The inlaid anti-slip epoxy color coating is color fast and is available in eight standard colors which can be used in combination to generate numerous color themes due to the dual channel face design. ROPPE



# Roppe Metal Treads, Metal Stair Tread Nosings & Metal Flat Step



## Product Data

Section 9  
Resilient Flooring



treads are created using material which makes the tread resistant to marring, scratching and chipping. Roppe Metal Stair Treads, Metal Nosings & Metal Flat Steps are supplied pre-drilled with countersunk holes from the factory for a flush finish with mechanical fasteners.

### 3.3 Product Type and Dimensions – Metal Stair Treads

Overall Thickness: Nominal .25" (6.35mm)

Stocking Depth: Nominal 9" (228.6mm)

Stocking Lengths: Nominal 36" (mm) and 48" (mm) lengths.

Fractions of an inch is considered within acceptable tolerance.

Stocking Colors: All Black and Yellow & Black color Combination.

All stocked treads are available in either all Black or a combination of Yellow (front-channel) and Black (back-channel) in 9" (mm) Depths and 36" (mm) and 48" (mm) Lengths.

Stocking Colors and Dimensions Lead Time: Normal Roppe lead time requirements.

Minimum Orders: No minimums required.

Nose Profile: 90 degree square nose.

Factory Pre-Drilled and Counter-Sunk Holes Approximate Measurements:

- 7.5" Tread Depths: Pre-factory holes are drilled 1 1/8" from the Front edge and 1 1/8" from the Back edge.
- 9" Tread Depths: Pre-factory holes are drilled 1 1/2" from the Front edge and 1 5/8" from the Back edge.
- 11" Tread Depths: Pre-factory holes are drilled 1 7/16" from the Front edge and 1 11/16" from the Back edge.
- Pre-factory drill holes are placed on approximately twelve (12") inches on center for all tread dimensions.
- Factory Pre-Drilled and Counter-sunk holes apply to all product dimensions.
- Drill holes by Tread Lengths: 12" – 21" = 4, 22" – 32" = 6, 33" – 45" = 8, 46" – 62" = 10, 63" x 75" = 12, 76" x 92" = 14, 93" x 113" = 16 and 114" – 120" = 18.
- 

Weight per Lineal Foot:

- 7.5" Depths: 1.9lb per lineal foot.
- 9" Depths: 2.2lb per lineal foot.
- 11" Depths: 2.76lb per lineal foot.



# Roppe Metal Treads, Metal Stair Tread Nosings & Metal Flat Step



## Product Data

Section 9  
Resilient Flooring



Roppe Treads 9" and 11" Depth Dimensions (not to scale):

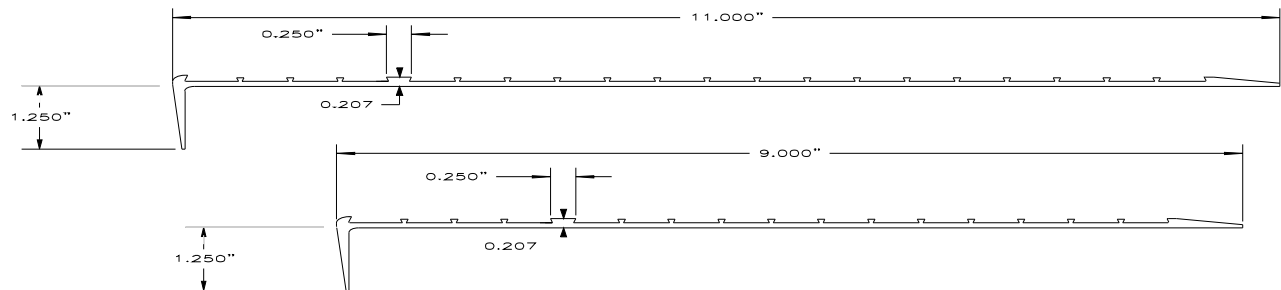

### 3.4 Special Dimensions and Standard and Custom Colors Availability:

#### 3.4.1 Special Order Dimensions

Sizes Available in lengths up to 144" (3.667.6mm) nominal.

Special Order Depths: 7.5" (109.5mm) and 11" (279.4mm) nominal.

Overall Thickness: Nominal .25" (6.35mm)

Special Order Minimums: None

Nose Profile: 90 degree square nose.

Factory Predrilled and counter sunk holes.

Fractions of an inch is considered within acceptable tolerance.

#### 3.4.2 Standard Non-Stocking Colors

Standard Non-Stocking Colors: Grey, Yellow, Green, Blue, Red, Black and Brown (Single Color or Combinations)

Lead Time: 3 weeks.

Minimum Orders: No minimum order requirements.

#### 3.4.3 Custom Color Matching

Customer Colors available for an additional charge.

Minimum Custom Color Orders: No minimum order requirements.



# Roppe Metal Treads, Metal Stair Tread Nosings & Metal Flat Step



## Product Data

Section 9

Resilient Flooring



Custom Color Lead Time: 3 weeks.

- Custom Color Matching Available upon request for additional charge. All custom match colors require customer color sample submittal, approval and signoff prior to manufacturing. Once approval and signoff has been completed, order lead time will be approximately three (3) weeks.
- No returns will be accepted for custom, standard or stocking colors or for incorrectly measured material.

### 3.5 Mechanical Fasteners and Packaging

3.5.1 Wood Substrates: #10 Wood Decking Screws by two-inches (2") in length are available prepackaged with black screw heads consisting of eight (8) screws for the installation of three-foot tread lengths, and packaged twelve (12) screws for the installation of four-foot tread lengths.

3.5.2 Concrete Substrates: #10 Self Tapping Concrete Screws by inch and three-quarters (1 3/4") in length are available prepackaged with black screw heads consisting of eight (8) screws for the installation of three-foot length treads and packaged twelve (12) screws for installation of four-foot tread lengths.

- All mechanical fasteners sold in prepackaged quantities only.
- Individual mechanical fasteners packaging covers the installation of one (1) stair tread only, and quantities are packaged to install each tread according to the tread length ordered.

3.5.3 Metal Substrates: Requires either #10 Stainless Steel Machine Screws or #10 Stainless Steel Bolts and Nuts, including SAE Zinc Washers are required and can be purchased at major home center stores. The type of mechanical fasteners required will be dictated by the installation substrate surface (smooth, textured or diamond plated etc.) and stairway access.

- Drilling and Taping:
  - Stainless Steel Machine Screws: #10 Flat-Head or Phillips-Head.
  - Tap Drill Size – 0.159
  - Stainless Steel Screw Length: Due to various thicknesses of metal, screw depth should be established by the applicator.
- Drilling and Bolting:
  - Stainless Steel Bolts: #10 Flat-Head or Phillips-Head.
  - Stainless Steel Bolt Length: Due to various thicknesses of metal, screw depth should be established by the applicator.
  - Stainless Steel Nut #10.
  - Lock Washer: #10 SAE Zinc Washer.



# Roppe Metal Treads, Metal Stair Tread Nosings & Metal Flat Step



## Product Data

Section 9  
Resilient Flooring



### 3.5.4 Metal Stair Tread Nosing - Product Type and Dimensions

Depth: 4" Nominal

Overall Thickness: Nominal 0.22"

Length: 1 foot to 10 feet nominal lengths.

Fractions of an inch is considered within acceptable tolerance.

Available Colors: Standard Colors & Glow-in-the-Dark (one color only).

Mechanical Fasteners & Packaging: See Section 3.5.1 and 3.5.2 for details.

Product Diagram: See diagram located at end of document.

### 3.5.5 Metal Flat Step (No Nose) - Product Type and Dimensions

Depth: 7" Nominal

Overall Thickness: Nominal 0.22"

Length: 1 foot to 10 feet nominal lengths.

Fractions of an inch is considered within acceptable tolerance.

Mechanical Fasteners & Packaging: See Section 3.5.1 and 3.5.2 for details.

Product Diagram: See diagram located at end of document.

Available Colors: Standard Colors (one color only).

### 3.6 Features and Benefits

- Metal Stair Constructed of heat-treated exterior-grade aluminum 6063T3, with an epoxy filled face that increases slip resistance and is resistant to marring, scratching and chipping.
- Metal Stair Treads Meets ADA guidelines for the visually impaired when contrasting colors are selected.
- Factory pre-drilled and countersunk holes for a flush finish with mechanical fasters available.
- Stocked in 9" nominal depths and 36" and 48" lengths. Nominal 7-1/2" and 11" depths available by special order.



# Roppe Metal Treads, Metal Stair Tread Nosings & Metal Flat Step



## Product Data

Section 9  
Resilient Flooring



- Metal Stair Treads are available in 7 colorfast solid colors or two-color combinations. Select from Black, Red, Yellow, Green, Blue Gray or Brown and all available at a Single Price Point.
- Custom Color matching is available and ideal to show off school or corporate branding colors.

## 4. Technical Data

### 4.1.1 Technical & Specification Data (Metal Stair Tread, Metal Stair Nosing & Metal Flat Step)

4.1.2 ASTM E 648 (NFPA 253), Critical Radiant Flux: Class 1, > 1.00 W/cm<sup>2</sup>

4.1.3 ASTM E 662 (NFPA 258), Specific Optical Density of Smoke Generated by Solid Materials: Passes, < 450

4.1.4 ASTM D 2047, Static Coefficient of Friction (Slip Resistance): Exceeds A.D.A. recommendations of > 0.60 for flat surfaces & > 0.80 for ramps using Neolite sensors.

4.1.5 A.D.A. Visually-Impaired: Yellow and Black color combination treads meet A.D.A. recommendations for contrasting colors.

4.1.6 Passes California State Code Title 24 for clearly contrasting color combinations.

### 4.2 Architects' Material Specifications – ROPPE METAL STAIR TREADS

All aluminum treads shown in the finish schedule or listed in this specification for heavy traffic areas shall be Roppe Metal Stair Treads as furnished by Roppe Corporation, Fostoria, Ohio. Roppe Metal Stair Treads aluminum base shall be constructed of heat treated exterior grade aluminum 6063T3 and filled with a UV stable, chemical resistant closed cell anti-slip epoxy coating combined with mineral abrasive grits that are uniform through-out providing anti-slip properties and construction of first quality materials, and shall be smooth and free of imperfections which detract from its appearance and contain no asbestos fiber. Roppe Metal Stair Treads shall be .250" (6.35 mm) nominal thickness, shall conform to industry standards. Roppe Metal Stair Treads shall be .250" (6.35mm) in nominal thickness, \_\_\_\_ (mm) in nominal depth, \_\_\_\_\_ (mm) in nominal length and in either single color or color combinations \_\_\_\_\_ stated.

### 4.3 Architects' Material Specifications – ROPPE METAL STAIR TREAD NOSING & METAL FLAT STEP

All aluminum stair tread nosing and metal flat step shown in the finish schedule or listed in this specification for heavy traffic areas shall be Roppe Metal Stair Nosing and/or Roppe Metal Flat Step as furnished by Roppe Corporation, Fostoria, Ohio. Roppe Metal Stair Nosing & Roppe Metal Flat Step's aluminum base shall be constructed of heat treated exterior grade aluminum 6063T3 and filled with a UV stable, chemical resistant closed cell anti-slip epoxy coating combined with mineral abrasive grits that are uniform through-out providing anti-slip properties



# Roppe Metal Treads, Metal Stair Tread Nosings & Metal Flat Step



## Product Data

Section 9

Resilient Flooring



and construction of first quality materials, and shall be smooth and free of imperfections which detract from its appearance and contain no asbestos fiber. Roppe Metal Stair Tread Nosing and Metal Flat Step shall be 0.22" in nominal thickness, \_\_\_\_ (mm) in nominal depth, \_\_\_\_\_ (mm) in nominal length and in either single color or color combinations \_\_\_\_\_ stated.

## 5. Product Limitations/Precautions

Roppe Metal Stair Treads, Metal Stair Nosings & Metal Flat Step must be installed using both the recommended adhesive and mechanical fasteners applicable to the type of surface (stairs/landings) the treads are being installed over, while strictly following the required procedures and installation instructions. DO NOT install ROPPE Treads without using both the recommended adhesive and mechanical fasteners, and do not install directly over deteriorated or deteriorating wood, metal or concrete, or over non-approved substrates! If there are any questions or concerns regarding the installation, safety or correct procedures, DO NOT proceed with the installation without first contacting Roppe. Roppe Metal Stair Treads, Metal Stair Nosing and Metal Flat Step must be installed in accordance with Roppe's recommendations in order for the product warranty to be in effect. As with any exterior product, Roppe Metal Stair Treads, Metal Stair Nosings, Metal Flat Step and mechanical fasteners can ice over under certain conditions and become slippery. Always remove both ice and snow prior to exposing Roppe Metal Stair Treads, Metal Stair Nosings & Metal Flat Step to foot traffic, and maintain free of snow and ice thereafter. Extreme temperatures changes combined with constant flexing of the treads and substrate/steps can loosen the mechanical fasteners which will require periodic checking and tightening to ensure a successful and safe installation. Mechanical fastener tightening and adjusting is the consumer's direct and sole responsibility which must be conducted on a routine basis to avoid potential safety hazards resulting from loose treads and/or protruding mechanical fasteners. DO NOT allow the mechanical fasteners to protrude above the treads face in order to avoid a potential trip hazard and loose treads. Always protect the treads from rolling loads and lateral shear stress. Roppe Metal Stair Treads, Metal Stair Nosings, Metal Flat Step may be stained if it is allowed to remain in contact with rubber products that may contain staining ingredients such as tires, casters, and walk-off mats. It is the consumer's responsibility to assure that disinfectants, cleaning agents, or other chemicals that may come in contact with the treads will not produce permanent discoloration and/or deterioration. As with any product, exposure to extreme, harsh conditions such as salt water and rock salt will have an adverse effect on the treads, adhesive and mechanical fasteners causing corrosion and deterioration. Roppe Metal Stair Treads, Metal Stair Nosings, Metal Flat Step may be used in or near commercial kitchens or in areas exposed to animal fats, greases, oils, solvents, strong detergents, only if the material is cleaned daily removing any and all residue. Do not expose Roppe Metal Stair Treads, Metal Stair Nosings, Metal Flat Step to oil, solvents, strong detergents nor any product which will have an adverse affect. Follow all local, state, and federal safety standards and practices. A premium exterior polyurethane adhesive approved by the adhesive manufacturer for bonding aluminum to either concrete, exterior grade plywood or metal is required and can be obtained at most home center stores. Coverage will



# Roppe Metal Treads, Metal Stair Tread Nosings & Metal Flat Step



## Product Data

Section 9

Resilient Flooring



depend on both the length and depth of the treads being installed. Typical, a 30oz tube of adhesive will cover approximately three 9-inch depth by four-foot length treads. The adhesive creates a seal between the steps and treads preventing water from seeping beneath the Metal Stair Treads, Metal Stair Nosings and Metal Flat Step, in addition to adding adhesion value to the installation and minimizing mechanical fasteners from loosening and protruding above the materials surface. The adhesive is also utilized as a sound buffer between the material and steps for added acoustical value. All step surfaces must be level, smooth, clean and dry before the installation and remain so for at least 72 hours to allow the adhesive to properly cure. Metal Stair Treads, Metal Stair Nosings and Metal Flat Step should not be installed in temperatures below 65°C. Follow all, state, federal, and adhesive manufacturer's safety standards for the use of all products and equipment. Caution: Some adhesives are not recommended for indoor installations due to Flammability! DO NOT drop heavy objects on the Metal Stair Treads, Metal Stair Nosings and Metal Flat Step as the epoxy coating may chip or crack.

## 6. Installation

### 6.1 General Preparation and Conditioning

Read all literature concerning ROPPE Metal Stair Treads, Metal Stair Nosings and Metal Flat Step product description, limitations, installation instructions, precautions, warnings, approved substrates, recommended adhesive type and mechanical fastener information, product maintenance, and warranty statement before installing ROPPE Metal Stair Treads, Metal Stair Nosings and Metal Flat Step. All materials are to be delivered to the installation location in its original packaging with labels intact. Store products in a dry area protected from the weather on a smooth, flat, dry surface with temperatures maintained between 65°F (19°C) and 85°F (30°C). Remove all plastic wrapping and strapping from the pallets or cartons prior to installation. DO NOT stack either the treads or tread cartons! The installation area, substrate, mechanical fasteners, treads and adhesive are to be maintained between 65°F (19°C) and 85°F (30°C) for at least 48 hours before installation, during installation, and 48 hours after the installation. Inspect all material for proper type, proper mechanical fasteners, tread size, color, thickness, and quality. DO NOT install material with obvious defects or if incorrect mechanical fasteners have been received or purchased separately. Conduct the proper moisture emission and pH testing on concrete substrates. Proceed with the installation only when the conditions are proper and correct, and the substrate is completely dry. Calcium Chloride Moisture Readings above 4.0 lbs is a clear indication that moisture is present and corrective measures must be taken before installing the Metal Stair Treads, Metal Stair Nosings and Metal Flat Step. Close the area to traffic of any kind during tread installation and 24-48 hours after the installation. Install Metal Stair Treads, Metal Stair Nosings and Metal Flat Step only after other finishing operations, including painting, have been completed. If the back of the Metal Stair Treads, Metal Stair Nosings and Metal Flat Step becomes soiled prior to installation, clean with a soft cloth dampened with a mild soap and water solution, rinse, let dry. Warning: Follow all local, state, and federal standards and practices for the proper removal and disposal of flooring, new or existing treads, adhesives, while also following all local, state, federal, and manufacturer's



# Roppe Metal Treads, Metal Stair Tread Nosings & Metal Flat Step



## Product Data

Section 9

Resilient Flooring



safety standards for the use of all products and equipment. If desired, paint stringers, risers, including stair areas not being covered by ROPPE Metal Stair Treads, Metal Stair Nosings and Metal Flat Step prior to installation. ONLY paint 1/4" inside the perimeter of the Metal Stair Treads, Metal Stair Nosings and Metal Flat Step being installed. DO NOT paint directly beneath the Metal Stair Treads, Metal Stair Nosings and Metal Flat Step since the paint will interfere with the adhesive bonding process which can also result in the paint releasing directly from the substrate resulting in an installation failure and potential liability hazard! Product, surface and ambient temperatures must be above 65° degrees before installation. Follow all local, state, federal, and manufacturer's safety standards for the use of all products and equipment.

## 6.2 Subfloor/Substrate Inspection and Preparation

6.2.1 All subfloors/substrates must be inspected prior to installation. All substrates must be clean, smooth, permanently dry, flat, and structurally sound. The substrate must be free of moisture, dust, sealers, paint, curing compounds, parting agents, residual adhesives, adhesive removers, hardeners, resinous compounds, solvents, wax, oil, grease, asphalt, gypsum compounds, alkaline salts, excessive carbonation or laitance, mold, mildew, any other extraneous coatings, films, materials and all other foreign matter which might interfere/restrict proper adhesive bonding resulting in an installation failure and potential liability hazard! DO NOT use sweeping compounds, solvents, citrus adhesive removers, or acid etching to clean the substrate. DO NOT install treads over gypsum-based or plaster based leveling or patching compounds. DO NOT install new treads over old floor covering, as the old floor covering may not be adequately bonded, hide possible structural defects, or may release resulting in an installation failure. In renovation or remodel work, remove all existing \*adhesive residue so that 100% of the overall area of the original subfloor/substrate is exposed. Follow The Resilient Floor Covering Institute's (RFCI) "Recommended Work Practice for Removal of Existing Floor Covering and Adhesive", and all applicable industry, local, state, and federal standards. Care must be taken to analyze the conditions and correct any problems prior to installation. Follow the manufacturer's recommendations for any Portland-based patching or underlayment materials which are approved by the manufacturer for exterior installations over concrete, exterior plywood and metal, excluding gypsum based or plaster based levelers or patching compounds.

\* Some previous manufactured asphaltic "cutback" contained asbestos. For removal instructions, refer to the Resilient Floor Covering Institute's publication "Recommended Work Practices for Removal of Resilient Floor Covering".

6.2.2 Concrete substrates on all Grade Levels must be tested in accordance with ASTM F 1869 to quantitatively determine the amount of moisture vapor emission at least one week prior to the installation. CAUTION: Calcium Chloride test cannot predict long-term moisture conditions of concrete slabs. Moisture testing only indicates moisture conditions at the time the tests are performed. Before conducting a Calcium Chloride test, the installation area must be maintained between 65°F (19°C) and 85°F (30°C) for at least 48 hours prior to testing, during testing and



# Roppe Metal Treads, Metal Stair Tread Nosings & Metal Flat Step



## Product Data

### Section 9

### Resilient Flooring



thereafter. In addition, the concrete's temperature range must also be identical to that of the installation area. Conduct two Calcium Chloride tests for the each flight of stairs and landing. The moisture emission shall not exceed 4.0 pounds per 1000 square feet per 24 hours. If the substrate does not meet the moisture emission requirement, the treads should not be installed until the problem has been corrected. DO NOT install the flooring if there is hydrostatic pressure. Every concrete floor slab on-grade or below grade to receive resilient treads shall have a permanent, effective moisture vapor retarder installed below the slab. A pH test must be performed to test for excessive alkalinity using a pH pencil or litmus paper and deionized water. A scaly, sandy, or powdery surface is an indication of some form of contaminant, usually excessive alkalis or an alkali-silica residue. A pH reading higher than 8 is an indication of a potential problem and the concrete must be neutralized by rinsing with clear water. Apply clear water with a mop and allow to dry. Re-rinse with clear water, allow to dry and retest to ensure pH level is within acceptable range of 5 to 8 on the pH scale. Continue to neutralize until the pH level is acceptable. The testing of concrete for alkalinity indicates the degree of alkalinity only at the time the test is conducted, and cannot be used to predict long-term conditions. Moisture and alkali salts in the concrete can cause the following problems after installation: adhesive deterioration and tread corrosion. DO NOT install treads over burnished (slick troweled) concrete to avoid adhesive and underlayment patch or self-leveling bonding problems due to the non-porosity of the concrete finish. Corrective measures such as bead blasting (shot blasting) or scarifying must be performed prior to installation. The concrete slab/substrate must be of good quality, standard density concrete with low water/cement ratios consistent with placing and finishing requirements, having a maximum slump of 4", a minimum compressive strength of 3500 psi, and following the recommendations of ACI Standard 302.1R-96 for class 2 or class 4 floors and the Portland Cement Association's recommendations for slabs on ground. Joints such as expansion joints, contraction joints, isolation joints, or other moving joints shall not be filled with patching compound or covered with resilient flooring. Expansion joint covers designed for use with resilient flooring should be used. Any surface cracks, grooves, depressions, saw cuts, control joints or other non-moving joints, and other irregularities shall be filled and smoothed with a high quality grade Portland cement-based, water resistant, non-shrinking, non-staining, mildew resistant, alkali resistant underlayment having a minimum compressive strength of 3500 psi after 28 days. Some underlayments may fail under excessive weight; an epoxy caulking compound may be required for certain repairs. Mechanically cleaning the substrate by shot-blasting, scarifying, or sanding shall be performed to achieve a flat, smooth, clean surface to prevent irregularities, roughness, or other defects from telegraphing through the new resilient flooring. The surface of the concrete shall be flat to within the equivalent of 3/16" in 10 feet, as described in ACI 117R. The surface shall be cleaned of all loose material by scraping, brushing, vacuuming, or other methods, or a combination thereof, immediately before commencing installation of resilient flooring. Follow the proper safety practices during the preparation and installation. Follow the recommendations of the American Concrete Institute (ACI 302.1R, Guide for Concrete Floor and Slab Construction; ACI 360.R, Design of Slabs on Grade; ACI 223, Standard Practice for the Use of Shrinkage-Compensating Concrete); The American Society for Testing and Materials (ASTM F 710, Standard Practice for



# Roppe Metal Treads, Metal Stair Tread Nosings & Metal Flat Step



## Product Data

Section 9

Resilient Flooring



Preparing Concrete Floors and Other Monolithic Floors to Receive Resilient Flooring), and the American National Standards Institute (ANSI A157.1, Recommended Practice for Concrete Floor and Slab Construction) for the preparation of concrete to receive resilient flooring or ROPPE Treads.

6.2.3 Wood Substrates/Subfloors/Stairs should be of double layer construction with a minimum thickness of 1" or otherwise specified by local and state building codes for either interior or exterior steps or landings. Crawl spaces underneath wood subfloors shall be in compliance with local building code ventilation practices and have clearance of at least 18" of cross-ventilated space between the ground level and joists. Wood joists should be spaced on not more than 16" centers. Place a moisture retarder; having a maximum rating of 1.0 perm, on the top of the ground under the wood subfloor overlapped at least 8". APA, The Engineered Wood Association, Underlayment Grade Plywood, minimum 3/8" thick, with a fully sanded face is to be used. Use APA approved exterior grade plywood if finished floors or steps are subjected to moisture. OSB, lauan, maranti, solid-core mahogany, waferboard, particleboard, chipboard, flakeboard, tempered hardboard, glass mesh mortar units or cementitious tile backer boards, sheathing-grade plywood, preservative-treated plywood, or fire-retardant treated plywood are not recommended as some manufacturers may use resins or other adhesives in the manufacturing of the product that may cause discoloration or staining of the treads or have an adverse effect on the adhesive, and may not be suitable for exterior installations. The warranties, performance, installation, and use are the responsibility of the manufacturer and/or contractor. DO NOT use plastic or resin filler to patch cracks. Installation on a sleeper, a wood subfloor system constructed over the top of concrete, is not recommended. Installation directly over Sturd-I-Floor panels is not recommended. All wood subfloors, single construction plywood floors, single and/or double tongue-and-groove strip floors, and wood plank floors must be prepared to receive resilient flooring or treads in accordance with federal and industry standards. Follow the recommendations of the APA, The Engineered Wood Association, Design/Construction Guide, Residential and Commercial, and ASTM F 1482, Standard Guide to Wood Underlayment Products Available for Use Under Resilient Flooring, for the installation and proper construction of the panels to receive resilient flooring or steps/stairs. It is the contractor's responsibility to determine if the subfloor is acceptable to receive the treads. Refer to 6.2.1. Replace any areas of wood that are bowed or severely worn, creating a flat, smooth, level surface. Ensure the surface is clean using an industrial cleaner. Rinse the surface thoroughly to remove any soap residue.

6.2.4 Terrazzo and ceramic floors are not recommended as suitable substrates for the installation of ROPPE Treads.

6.2.5 Metal floors to be used as subfloors, landings or stairs must be thoroughly cleaned of any residue, oil, rust, paint, primers, and oxidation. Metal must also be properly sanded/grinded to provide an oxidation free, smooth, level, clean substrate and structurally sound to receive the treads. The treads must be installed within 4 hours after sanding/grinding to prevent the metal



# Roppe Metal Treads, Metal Stair Tread Nosings & Metal Flat Step



## Product Data

Section 9

Resilient Flooring



surface from re-oxidizing. Deflection of the metal floor can cause a bond failure between the treads, adhesive and the metal substrate. On an extremely smooth, non-porous, metal substrate, a longer “tack up” may be required in order to prevent the adhesive from oozing outside the perimeter of the treads.

### 6.3 Adhesive Application

#### 6.3 Adhesive Application

6.3.1 Premium Grade Exterior Grade Polyurethane Adhesive and Application. A Premium grade exterior polyurethane adhesive approved by the adhesive manufacturer for bonding aluminum directly to concrete, exterior grade plywood or metal is required and can be obtained at most major home center stores. Adhesive must be used in conjunction with mechanical fasteners. DO NOT install ROPPE Treads without using both the proper adhesive and mechanical fasteners. Read all installation literature before proceeding. Follow safety precautions on the adhesive label and Material Safety Data Sheet. Caution: Some adhesives are not recommended for indoor installations since they may be either Flammable or Extremely Flammable! If installing Metal Stair Treads, Metal Stair Nosings and Metal Flat Step indoors, a similar manufacturer recommended non-flammable adhesive must be used. Caution: DO NOT use adhesive near any flame, sparks, battery or electrically operated equipment, or any other apparatus that could generate a spark or static electricity that could ignite the vapors. The adhesive selected must be recommended for either indoor or outdoor installations depending on the particular application, which can be used over porous and non-porous substrates. When used on non-porous substrates, the adhesive must be allowed to “flash off”, but not allowed to get dry to the touch. Rain or exposure to moisture within 72 hours after installation may slow the set up time, and may adversely affect the adhesive. Coverage will depend on both the length and depth of the treads being installed. Typical, a 30oz tube of adhesive will cover approximately three nine-inch depth by four-foot length treads. The adhesive creates a seal between the steps and material preventing water from seeping beneath the material, in addition to adding adhesion value to the installation. The adhesive is also utilized as a sound buffer between the material and steps for added acoustical value; and will assist in minimizing mechanical fasteners from protruding upward under normal use and also during extreme temperature ranges resulting in both substrate and treads flexing causing a potential safety and trip hazards. Metal Stair Treads, Metal Stair Nosings and Metal Flat Step should not be installed in temperatures below 65°C. Follow all, state, federal, and adhesive manufacturer’s safety standards for the use of all products and equipment. DO NOT drop heavy objects on the treads as the epoxy filler may chip or crack. Before applying adhesive, first clean the back of material with soap and water and rinse to remove any residual film or dirt which will interfere with the adhesive’s bond. Once the material has been cleaned and allowed to dry, apply a 1/2” bead of adhesive around the perimeter of the material, around each factory predrilled hole, inside the on-site drill hole drilled in the substrate, in addition to a tight serpentine pattern covering 75% of the materials back. If there is a large radius at the front nose step, apply one or two beads of adhesive at the nose location for a secure fit. The adhesive must be applied approximately 3/4” from the perimeter and a 1/2” from the predrilled factory holes to prevent oozing outside the material and factory



# Roppe Metal Treads, Metal Stair Tread Nosings & Metal Flat Step



## Product Data

Section 9

Resilient Flooring



drilled holes once installed. In order to achieve a successful adhesive bond and to prevent hollow spots, each step must be completely flat, structurally sound, clean and thoroughly dry.

Ensure adhesive selected confirms with California Rule #1168 pertaining to Calculated VOC's. If unsure, check first with the adhesive manufacturer before using. ROPPE does not assume any product or performance liability pertaining to the adhesive selected.

6.4 ROPPE Metal Stair Treads, Metal Stair Nosings and Metal Flat Step Job-Site Measuring: Roppe Metal Stair Treads, Metal Stair Nosings and Metal Flat Step like similar exterior and interior material, are not designed to cover the entire step surface nor is it recommend since the Metal Stair Treads, Metal Stair Nosings and Metal Flat Step are custom cut, and cannot be altered on the job-site without distorting the materials appearance. It is recommended to leave a two-inch (2") space around both sides and back of each Metal Stair Treads, Metal Stair Nosings and Metal Flat Step. This will allow the Metal Stair Treads, Metal Stair Nosings and Metal Flat Step to be centered for each step and uniform down the flight of stairs. It is recommended that all steps being covered with material be measured individually and the smallest width and depth dimensions be considered as the actual step size for the entire flight of stairs. Once the shortest step dimensions (length and depth) have been established, two (2") inches is then subtracted from the depth and length of the shortest step dimensions, and submitted for manufacturing. As an example, if the smallest step tread depth is twelve-inches and the smallest steps length is four-feet & four-inches, your adjusted material order dimensions would be nine-inches in depth and four-feet in length. Be sure and always measure each step twice to ensure the correct measurements minus the perimeter spacing to ensure the treads will fit properly. The standard factory pre-drilled and counter-sunk hole patterns approximate locations for metal stair treads are noted in Section 3.3 and are positioned approximately twelve-inch (12") on center. It is the contractor's responsibility to ensure the pre-drilled hole patterns can be positioned on each step and not overlap any preexisting metal nosing, in addition to checking for proper clearance and spacing from the nose's edge allowing the mechanical fasteners to be installed. Any incorrectly measured Metal Stair Treads, Metal Stair Nosings and Metal Flat Step will not be accepted for return by either ROPPE or ROPPE's authorized distributors. It is the contractor's direct responsibility to ensure each Metal Stair Treads, Metal Stair Nosings and Metal Flat Step are properly measured before ordering allowing the necessary spacing around the treads sides and back to ensure a proper fit. It is also the contractor's responsibility to verify the pre-drilled factory holes can be successfully installed with the recommended mechanical fastener, in addition to not interfering or hampering with the application of mechanical fasteners by the stairs design or curvature of the stairs nosing from either above or beneath.

6.5 Roppe Metal Stair Treads, Metal Stair Nosings and Metal Flat Step Mechanical Fastener and Adhesive Installation Application

6.5.1 Installations over concrete & wood stairs: Center one Metal Stair Treads, Metal Stair Nosings or Metal Flat Step on the top step or landing and one on the bottom step. Once centered, strike a chalk line on one edge of the material from the top and bottom tread creating



# Roppe Metal Treads, Metal Stair Tread Nosings & Metal Flat Step



## Product Data

### Section 9

### Resilient Flooring



a straight line down the stairs. Once all material has been aligned with the straight line, each will then be centered in the stairs. Start by installing the top step or landing, first and work downward to prevent the materials from shifting. Place the top Metal Stair Treads, Metal Stair Nosings or Metal Flat Step on the step or landing and push back toward the steps nosing to ensure a tight fit. Use the materials pre-drilled holes as a location template and carefully punch the hole location transferring it onto the substrate/step. The Metal Stair Treads, Metal Stair Nosings and Metal Flat Step should only be used as a template for the stair in which it is being installed. Remove material and use a hammer drill with the appropriate drill bit and drill each hole 1/4" deeper than the length of the mechanical fasteners being used. Remove all dust created by drilling by either sweeping or by using a portable vacuum. Apply a 1/2" bead of adhesive around the perimeter of the material, around each factory predrilled hole, inside the on-site substrate drill holes, in addition to a tight serpentine pattern covering 75% of the materials backing. If there is a large radius at the front nose step, apply two beads of adhesive at the rounded location to ensure a tight fit. Screw the treads into place using the required mechanical fasteners, and install the remaining treads in the same manner. Allow the adhesive to cure for at least 24-48 hours before exposing to traffic of any kind. Protect the stairs from traffic until the adhesive has properly cured by posting the necessary warning signs. Refer to Section 6.3 for additional adhesive information and application and installation procedures. Mechanical fastener tightening and adjusting is the consumer's direct and sole responsibility which must be conducted on a routine basis to avoid potential safety hazards resulting from loose treads and/or protruding mechanical fasteners.

\* Tools needed for installations over concrete and wood stairs and landings: Electric or cordless hammer drill, chalk-line, measuring tape, screw driver, extension cord, hammer, punch, masonry or wood drill bits, mechanical fasteners, broom or portable vacuum, socket-set, vice-grips, adhesive and applicator.

#### 6.5.2 Installations over Metal Stairs:

6.5.3 Installations over Open Access Metal Stairs: Follow the same procedures listed in Section 6.3.1 and 6.5.1 regarding material layout, centering and adhesive application, including all warnings and precautions. Once the material has been centered and the drill hole pattern accurately marked on the metal step, drill completely through the metal step and install treads with both adhesive and stainless steel bolts, nuts and SAE Zinc washers, then install the remaining material in the same manner.

After installation, each bolt must be cut flush with the end of the nut due to potential health hazards and safety concerns. In some open access metal stairs, several of the bottom steps may need to be drilled and tapped if access is not available from beneath refer to Section 6.5.4. It is the installer's choice to either drill and tap the screw holes or drill completely through the steps utilizing the bolting system noted above in this section. Mechanical fastener tightening and adjusting is the consumer's direct and sole responsibility which must be conducted on a routine



# Roppe Metal Treads, Metal Stair Tread Nosings & Metal Flat Step



## Product Data

Section 9  
Resilient Flooring



basis to avoid potential safety hazards resulting from loose treads and/or protruding mechanical fasteners.

6.5.4 Installations over Closed Metal Stairs: Follow the same procedures listed in Section 6.3.1 and 6.5.1 regarding tread layout, centering and adhesive application, including all warnings and precautions. Once the material has been centered and the drill hole pattern accurately marked on the metal steps, drill holes approximately 1/4" deeper than the mechanical fasteners being used. If installing over a diamond plate surface, the center hole location may be on a sloped side of the diamond pattern, so punch center locations deeply and accurately to insure the correct positioning of the drill hole. Once the holes have been drilled, they must be tapped to fit the exact size of the mechanical fastener being installed. Once the drilled holes have been tapped and adhesive is applied as specifically noted in Section 6.3 and 6.5.1, install material with stainless steel machine screws, then install the remaining material in the same manner. Mechanical fastener tightening and adjusting is the consumer's direct and sole responsibility which must be conducted on a routine basis to avoid potential safety hazards resulting from loose material and/or protruding mechanical fasteners.

\* Tools needed for installation over metal steps and landings: Electric or cordless hammer drill, chalk-line, measuring tape, extension cord, hammer, punch, carbide-tip drill bits, metal tap, tap handle, screw driver, mechanical fasteners, broom or portable vacuum, adhesive and adhesive applicator.

## 7. Product Maintenance/Precautions

DO NOT perform any maintenance or expose the product to water, rain, cleaning or cleaning solutions/chemicals or other materials for at least 72 hours after installation to allow the adhesive to properly cure. Immediately remove any adhesive residue from the materials surface to prevent permanent discoloration. Remove any covering that may have been used to protect the material. The Metal Stair Treads, Metal Stair Nosings and Metal Flat Step must be properly installed with all mechanical fasteners and adhered completely with adhesive and cleaned before released for normal use. Sweep to remove dirt and other particulate. ROPPE Metal Stair Treads, Metal Stair Nosings and Metal Flat Step should be cleaned periodically to maximize the life and appearance of the material. If left un-cleaned, sand, grit, and grime buildup on the surface can become very abrasive reducing the life and appearance of the product. Metal Stair Treads, Metal Stair Nosings and Metal Flat Step can be cleaned using a general purpose industrial floor cleaner. First check for compatibility by testing cleaning products to assure damage does not occur on the materials colored face or aluminum. For encrusted dirt use a stiff bristled brush with an industrial cleaner to remove. Material can also be cleaned with a pressure washer not exceeding 1,000 psi. Pressure washing above 1,000 psi will damage the material and epoxy filled face. Interior treads may be swept, vacuumed and spot cleaned. A neutral pH cleaning solution or a mild soap and water solution may be used for shampooing. DO NOT use highly alkaline cleaners, highly acidic cleaners, or sweeping compounds containing oils or solvents. DO NOT allow cleaning solutions or other chemicals that could deteriorate the



# Roppe Metal Treads, Metal Stair Tread Nosings & Metal Flat Step



## Product Data

Section 9

Resilient Flooring



adhesive to stand on the flooring. Spills must be immediately removed from the flooring. Exterior installations can be simply hosed off and left to dry. Chewing gum can be removed by using Mellow Craft aerosol Chewing Gum Remover. Scuff marks can be removed from aluminum nose by scrubbing with a green Scotch-Brite Pad in the direction of the treads length.

## 8. Availability and Cost

**8.1** Products are available through Roppe distributors. Contact Roppe Customer Service at 1.800.537.9527 or visit [www.roppe.com](http://www.roppe.com) for a distributor near you.

**8.2** Samples may be obtained by may be obtained by calling Roppe Customer Service at 1.800.537.9527, or by visiting [www.roppe.com](http://www.roppe.com)

## 9. Technical Assistance

Technical service information and assistance may be obtained by calling Roppe Customer Service at 1.800.537.9527, or by visiting [www.roppe.com](http://www.roppe.com).

## 10. Limited Warranty

Roppe Corporation manufactures and markets its floor products under the trade name Roppe is warranted for a period of one (1) year from date of installation to be free of defects in material and workmanship. Roppe has a five (5) year Limited Wear Warranty on Metal Stair Treads, Metal Stair Nosings and Metal Flat Step if installed, maintained, and used strictly in accordance with Roppe's written instructions. Roppe will not warranty Aluminum Tread products against fading or discoloration when exposed to direct sunlight or indirect sunlight. This Limited Warranty only applies to Metal Stair Treads, Metal Stair Nosings and Metal Flat Step, which has been installed, maintained, and used strictly in accordance with Roppe's written instructions and is valid only under normal wear and traffic conditions in a use for which it was designed. Instructions may be obtained from a Roppe distributor or by writing Roppe, Attention: Internal Sales Manger, P.O. Box 1158, Fostoria, OH 44830. Notice of any defect must be made in writing to Roppe within thirty (30) days after buyer learns of the defect. No merchandise is to be returned prior to Roppe's inspection and written approval. Buyer's sole and exclusive remedy for breach of this Limited Warranty shall be a pro rata credit, based on the period remaining in this Limited Warranty, toward the purchase of new Metal Stair Treads, Metal Stair Nosings and Metal Flat Step, or in the event Metal Stair Treads, Metal Stair Nosings and Metal Flat Step are not available, other Roppe treads or products. Replacement credit shall be equal to the proportion of Limited Warranty time remaining multiplied by the current price of Metal Stair Treads, Metal Stair Nosings and Metal Flat Step or the last price if Metal Stair Treads, Metal Stair Nosings and Metal Flat Step are not available. In no event shall Roppe be liable for incidental or consequential damages, even if some other provision of this Limited Warranty is unenforceable. Buyer waives all other claims, and remedies against Roppe, whether statutory, based in common law or in equity, and including, but not limited to, direct, indirect, special,



# Roppe Metal Treads, Metal Stair Tread Nosings & Metal Flat Step



## Product Data

Section 9

Resilient Flooring



incidental, and consequential damages. In order to use this Limited Warranty, Buyer must present this Limited Warranty and proof of time of purchase to Buyer's Roppe representative. Roppe shall have no liability whatsoever to Buyer in the event the goods become defective if such defect is caused in whole or part by cuts, tears, vandalism, fire, willful destruction, improper installation, installed with obvious defects, damaged from high heels, spike footwear, or improper maintenance, accident or act of God. Products installed as "seconds", "mill runs", "non-conforming", not being of first quality, are sold 'as is" and Roppe makes no warranties whatsoever, expressed or implied, with respect thereto, including warranties of merchantability or fitness for a particular use. This Limited Warranty is valid only if Aluminum Treads are installed pursuant to the Limited Warranty, using Roppe's recommended mechanical fasteners and adhesive. These warranties are expressly in lieu of any other warranties expressed or implied, including, but not limited to any implied warranty of merchantability or fitness for a particular purpose. By retaining Roppe's merchandise for more than five (5) days after receipt of such merchandise, Buyer agrees that it accepts the terms of this Limited Warranty and that there are no warranties or rights beyond those contained herein. Read the Metal Stair Treads, Metal Stair Nosings and Metal Flat Step Product Data information concerning Product Limitations, Installation, and Maintenance available from a Roppe Distributor or Roppe Customer Service Representative.



# Roppe Metal Treads, Metal Stair Tread Nosing & Metal Flat Step



**Product Data**  
Section 9  
Resilient Flooring



Metal Stair Tread Nosing Diagram (not to scale)

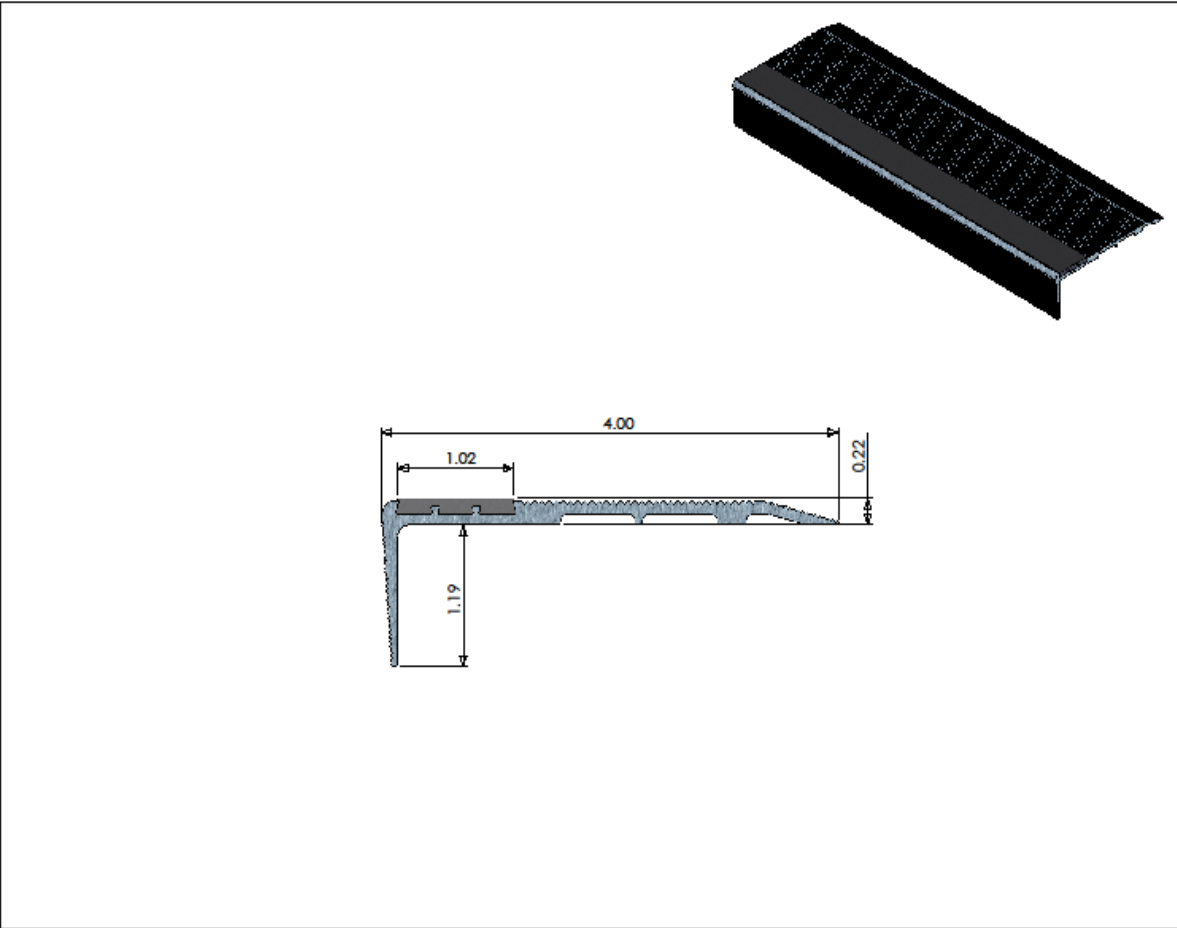

# Roppe Metal Treads, Metal Stair Tread Nosings & Metal Flat Step



**Product Data**  
Section 9  
Resilient Flooring



Metal Flat Step Diagram (not to scale)

